

Features

- Exceptional Broadband Performance
- Suitable for Higher Power WiMax & WLAN Applications
- Lower Loss:
 - Tx = 0.40 dB @ 3.8 GHz, 22mA
 - Rx = 0.60 dB @ 3.8 GHz, 22mA
- Higher Isolation:
 - Rx-Tx = 21 dB @ 3.8 GHz
 - Tx-Rx = 26 dB @ 3.8 GHz
- Higher RF Input Power = 10 W C.W. (Tx-Ant Port)
- Higher IIP3 = 65 dBm (Tx-Ant Port).
- Lower EVM (OFDM):
 - < 1.0% @ 8W Pin, (Tx-Ant Port)
- Lead-Free 3 mm 16-Lead PQFN Package
- 100% Matte Tin Plating over Copper
- Halogen-Free “Green” Mold Compound
- RoHS* Compliant and 260°C Reflow Compatible

Description

MA-COM's MASW-000822-12770T is a Broadband, high linearity, common anode PIN diode SPDT switch in a lead-free 3 mm 16-lead PQFN package. The MASW-000822-12770T is ideally suited for 0.05 - 6.0 GHz applications, including WiMax & WLAN.

This SP2T switch offers excellent isolation to loss ratio for both Tx and Rx states. The PIN diode provides exceptional 10 W C.W power handling coupled with 65 dBm IIP3 for maximum switch performance @ 3.8GHz.

This MASW-000822-12770T incorporates a PIN diode die fabricated with M/A-COM's patented Silicon-Glass HMIC™ process. This chip features two silicon pedestals embedded in a low loss, low dispersion glass. The diodes are formed on the top of each pedestal. The topside is fully encapsulated with silicon nitride and has an additional polymer passivation layer. These polymer protective coatings prevent damage and contamination during handling and assembly.

Functional Schematic

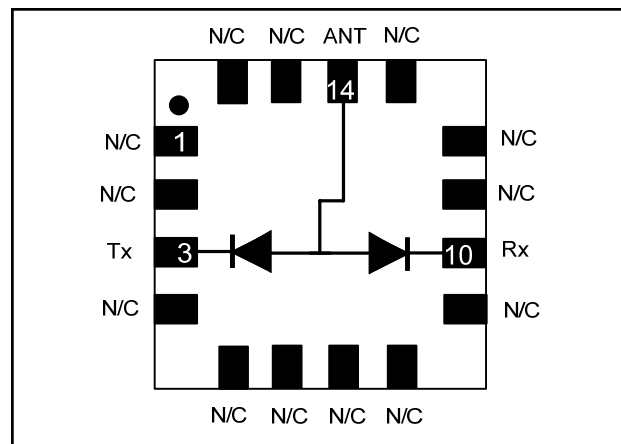

Pin Configuration ¹

Pin	Function	Pin	Function
1	N/C	9	N/C
2	N/C	10	Rx
3	Tx	11	N/C
4	N/C	12	N/C
5	N/C	13	N/C
6	N/C	14	Ant
7	N/C	15	N/C
8	N/C	16	N/C

1. The exposed pad centered on the package bottom must be connected to RF and DC ground.

Ordering Information ²

Part Number	Package
MASW-000822-12770T	13 inch, 3000 piece reel
MASW-000822-001SMB	Sample Board

2. Reference Application Note M513 for reel size information.

* Restrictions on Hazardous Substances, European Union Directive 2002/95/EC.

HMIC™ PIN Diode SP2T 10 Watt Switch for 0.05 - 6.0 GHz Higher Power Applications

M/A-COM Products
Rev. V3

Electrical Specifications: $T_A = 25^\circ\text{C}$, $P_{IN} = 0 \text{ dBm}$, $Z_0 = 50 \Omega$

Parameter	Conditions	Units	Min.	Typ.	Max.
Insertion Loss, Rx	Rx = +5.0 V @ +22 mA, Tx = +12V @ 0 mA 2.3 - 2.7 GHz 3.3 - 3.8 GHz 4.9 - 5.9 GHz	dB	—	0.55 0.60 0.80	0.70 0.75 0.90
Insertion Loss, Tx	Tx = +5.0 V @ +22 mA, Rx = +12V @ 0 mA 2.3 - 2.7 GHz 3.3 - 3.8 GHz 4.9 - 5.9 GHz	dB	—	0.35 0.40 0.50	0.45 0.55 0.60
Isolation, Tx to Rx	Tx = +5.0 V @ +22 mA, Rx = +12V @ 0 mA 2.3 - 2.7 GHz 3.3 - 3.8 GHz 4.9 - 5.9 GHz	dB	27.0 24.5 21.0	29.5 26.5 21.5	— — —
Isolation, Rx to Tx	Rx = +5.0 V @ +22 mA, Tx = +12V @ 0 mA 2.3 - 2.7 GHz 3.3 - 3.8 GHz 4.9 - 5.9 GHz	dB	22.5 19.5 17.5	24.5 21.5 17.5	— — —
Input Return Loss Tx	Tx = +5.0 V @ +22 mA, Rx = +12V @ 0 mA 2.3 - 2.7 GHz 3.3 - 3.8 GHz 4.9 - 5.9 GHz	dB	—	17 18 18	— — —
Input Return Loss Rx	Rx = +5.0 V @ +22 mA, Tx = +12V @ 0 mA 2.3 - 2.7 GHz 3.3 - 3.8 GHz 4.9 - 5.9 GHz	dB	—	17 18 18	— — —

Electrical Specifications: $F = 3.5 \text{ GHz}$, $T_A = 25^\circ\text{C}$, $Z_0 = 50 \Omega$ ^{3,4,5}

Parameter	Conditions	Units	Min.	Typ.	Max.
Tx Input P0.1dB	Tx = +5.0 V @ +22 mA, Rx = +12V @ 0 mA, Tx To Antenna	dBm	—	40	
Tx Input P1dB	Tx = +5.0 V @ +22 mA, Rx = +12V @ 0 mA, Tx To Antenna	dBm	—	45	—
Tx 2nd Harmonic	Tx = +5.0 V @ +22 mA, Rx = +12V @ 0 mA, Pin = + 30 dBm	dBc	—	-68	—
Tx 3rd Harmonic	Tx = +5.0 V @ +22 mA, Rx = +12V @ 0 mA, Pin = + 30 dBm	dBc	—	-84	—
Tx Input 3rd Order Intercept Point	Tx = +5.0 V @ +22 mA, Rx = +12V @ 0 mA, Pin = + 10 dBm F1 = 3.500 GHz, F2 = 3.510 GHz	dBm	—	65	—
Tx C.W. Input Power	Tx = +5.0 V @ +22 mA, Rx = +12V @ 0 mA, F = 4.0 GHz	dBm	—	—	40
Rx C.W. Input Power	Rx = +5.0 V @ +22 mA, Tx = +12V @ 0 mA, F = 4.0 GHz	dBm	—	—	33
Tx EVM (OFDM)	Tx = +5.0 V @ +22 mA, Rx = +12V @ 0 mA, Pin = +39 dBm	%	—	0.8	—
Tx EVM (OFDM)	Tx = +5.0 V @ +22 mA, Rx = +12V @ 0 mA, Pin = +40 dBm	%	—	1.2	—
Tx RF Switching Speed	(10-90% RF Voltage) Tx = +5.0 V @ +22 mA, Rx = +12V @ 0 mA 1MHz Rep Rate in Modulating Mode	ns	—	<500	—

3. Data taken at device RF leads.
4. Typical PIN diode forward voltage = +0.8 V @ 10 mA, +0.85 V @ 22 mA.
5. Typical PIN diode reverse voltage = +12.0 V

2

ADVANCED: Data Sheets contain information regarding a product M/A-COM is considering for development. Performance is based on target specifications, simulated results, and/or prototype measurements. Commitment to develop is not guaranteed.

PRELIMINARY: Data Sheets contain information regarding a product M/A-COM has under development. Performance is based on engineering tests. Specifications are typical. Mechanical outline has been fixed. Engineering samples and/or test data may be available. Commitment to produce in volume is not guaranteed.

• **North America** Tel: 800.366.2266 / Fax: 978.366.2266

• **Europe** Tel: 44.1908.574.200 / Fax: 44.1908.574.300

• **Asia/Pacific** Tel: 81.44.844.8296 / Fax: 81.44.844.8298

Visit www.macom.com for additional data sheets and product information.

M/A-COM Inc. and its affiliates reserve the right to make changes to the product(s) or information contained herein without notice.

HMIC™ PIN Diode SP2T 10 Watt Switch for 0.05 - 6.0 GHz Higher Power Applications

M/A-COM Products
Rev. V3

Absolute Maximum Ratings ⁶ @ T_A = +25 °C (unless otherwise specified)

Parameter	Absolute Maximum
Forward Current	+ 100 mA
Reverse Voltage	-100 V
Operating Temperature	-40 °C to +85 °C
Storage Temperature	-55 °C to +150 °C
Junction Temperature	+175 °C
Tx Incident C.W. Power	10 W C.W.
Tx Peak Incident Power	20 W, 3 μS P.W., 1% Duty
Rx Incident C.W. Power	2 W C.W.
Mounting Temperature	+260°C for 10 seconds

6. Exceeding these limits may cause permanent damage.

Cross Section View of M/A-Com PCB

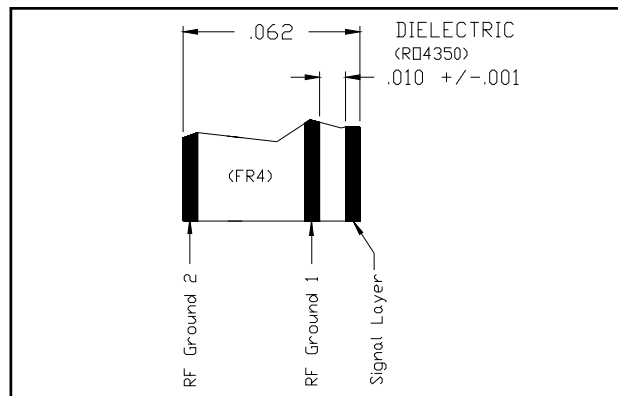

D.C. Bias to RF Truth Table

RF State	TTL & D.C. Bias Conditions	Voltage at Common Anode
Low Loss Tx-Ant & Isolation Tx-Rx	TTL = 1 + 5V @ 22 mA (Tx), + 12V @ 0 mA (Rx)	+ 0.9 V
Low Loss Ant-Rx & Isolation Rx-Tx	TTL = 0 + 5V @ 22 mA (Rx), + 12V @ 0 mA (Tx)	+ 0.9 V

Driver and SP2T Schematic with Positive Voltage ^{7,8,9,10,11}

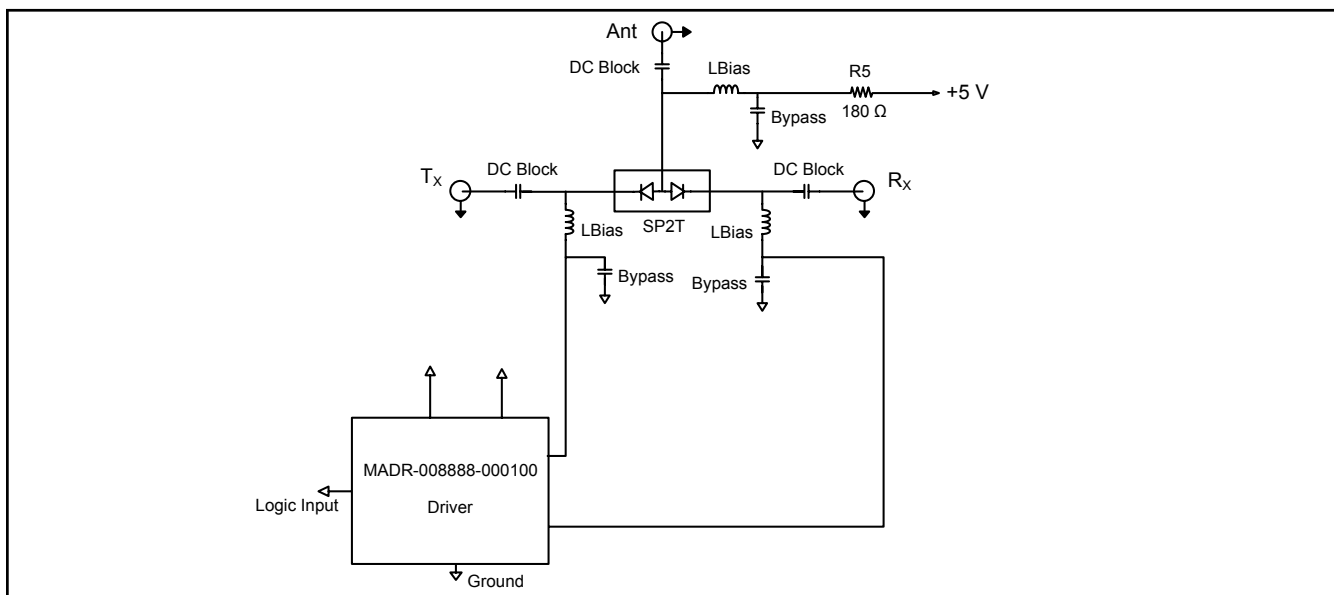

- 7. Forward Bias Diode Voltage, ΔVf @ 22 mA = + 0.9 V.
- 8. Reverse Bias Diode = | - (+12 V - +0.9 V) | = | - 11.1 | V.

ADVANCED: Data Sheets contain information regarding a product M/A-COM is considering for development. Performance is based on target specifications, simulated results, and/or prototype measurements. Commitment to develop is not guaranteed.

PRELIMINARY: Data Sheets contain information regarding a product M/A-COM has under development. Performance is based on engineering tests. Specifications are typical. Mechanical outline has been fixed. Engineering samples and/or test data may be available. Commitment to produce in volume is not guaranteed.

- **North America** Tel: 800.366.2266 / Fax: 978.366.2266
- **Europe** Tel: 44.1908.574.200 / Fax: 44.1908.574.300
- **Asia/Pacific** Tel: 81.44.844.8296 / Fax: 81.44.844.8298

Visit www.macom.com for additional data sheets and product information.

M/A-COM Inc. and its affiliates reserve the right to make changes to the product(s) or information contained herein without notice.

Typical Performance Curves: $T_A = 25^\circ\text{C}$, $Z_0 = 50 \Omega$

Insertion Loss

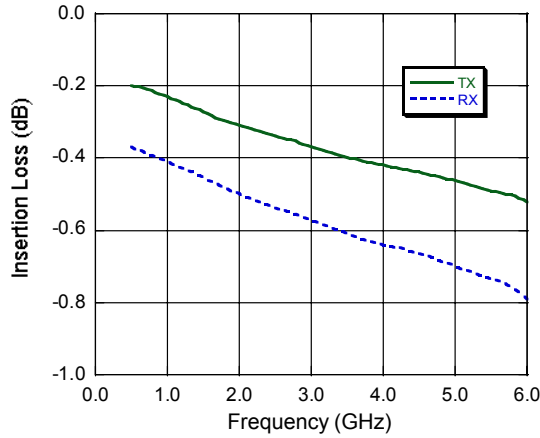

Isolation

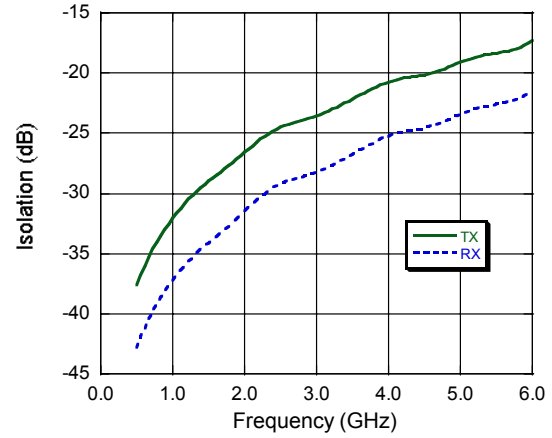

Tx and RX Return Loss

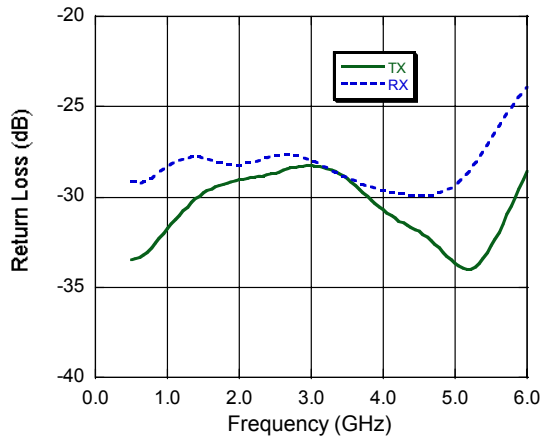

EVM

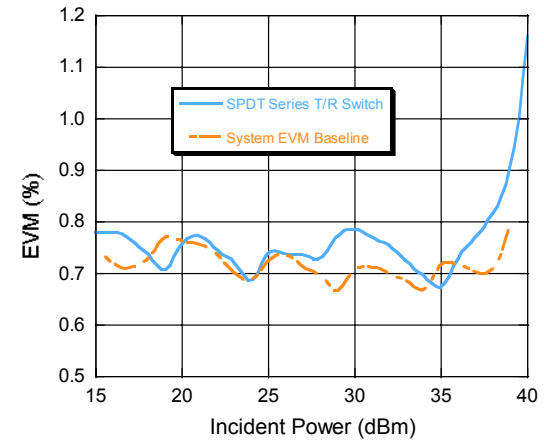

HMIC™ PIN Diode SP2T 10 Watt Switch for 0.05 - 6.0 GHz Higher Power Applications

M/A-COM Products
Rev. V3

Tx Diode Junction Temperature vs. C.W. Input Power @ 4.0 GHz, T_j = 175°C

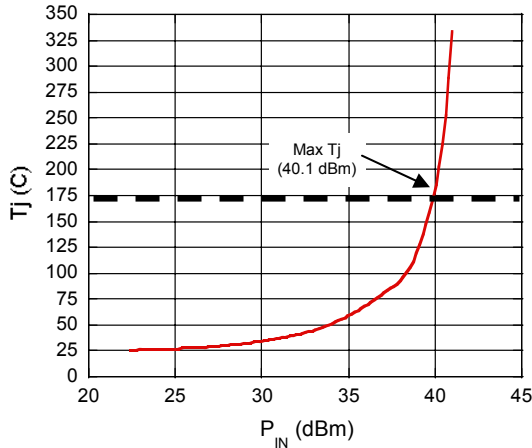

⚠ This device is not for saturation power application. Exceeding power dissipation maximum rating might result in device failure.

Handling Procedures

Please observe the following precautions to avoid damage:

Static Sensitivity

These devices are rated at Class 1B Human Body. Proper ESD control techniques should be used when handling these devices.

Lead-Free 3 mm 16-Lead PQFN†

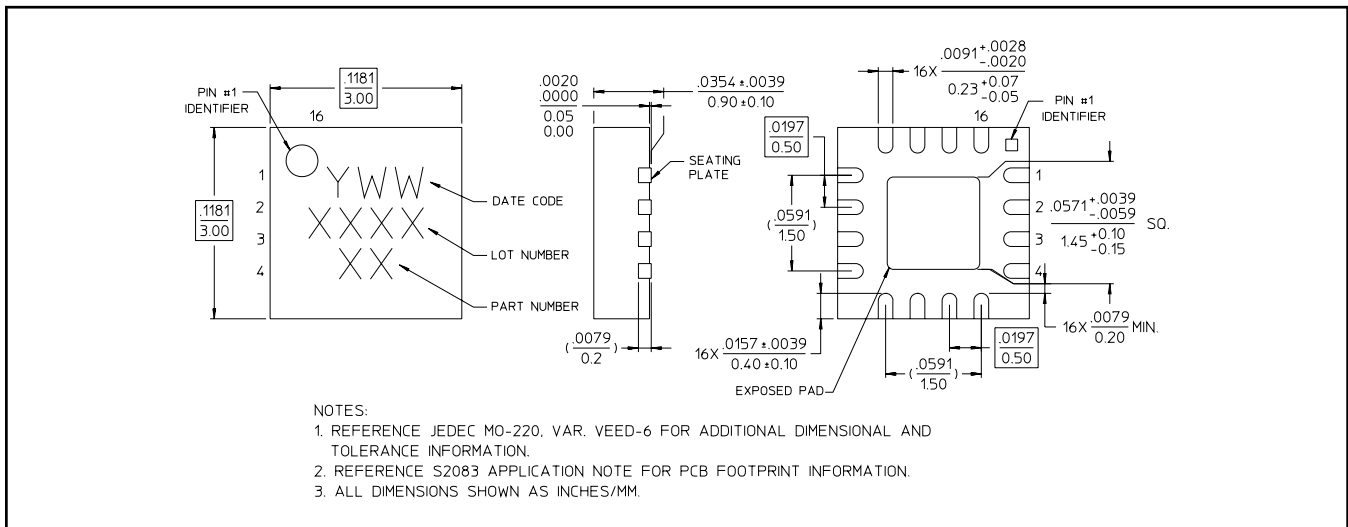

† Reference Application Note M538 for lead-free solder reflow recommendations. Meets JEDEC moisture sensitivity level 1 requirements.

ADVANCED: Data Sheets contain information regarding a product M/A-COM is considering for development. Performance is based on target specifications, simulated results, and/or prototype measurements. Commitment to develop is not guaranteed.

PRELIMINARY: Data Sheets contain information regarding a product M/A-COM has under development. Performance is based on engineering tests. Specifications are typical. Mechanical outline has been fixed. Engineering samples and/or test data may be available. Commitment to produce in volume is not guaranteed.

- **North America** Tel: 800.366.2266 / Fax: 978.366.2266
- **Europe** Tel: 44.1908.574.200 / Fax: 44.1908.574.300
- **Asia/Pacific** Tel: 81.44.844.8296 / Fax: 81.44.844.8298

Visit www.macom.com for additional data sheets and product information.

M/A-COM Inc. and its affiliates reserve the right to make changes to the product(s) or information contained herein without notice.